

European Energy Awards – 06.11.2025

ENERGYPOLIS - Urban Energy Systems Lab

Jessen Page (jessen.page@hevs.ch)



Ronquoz21 (Masterplan)

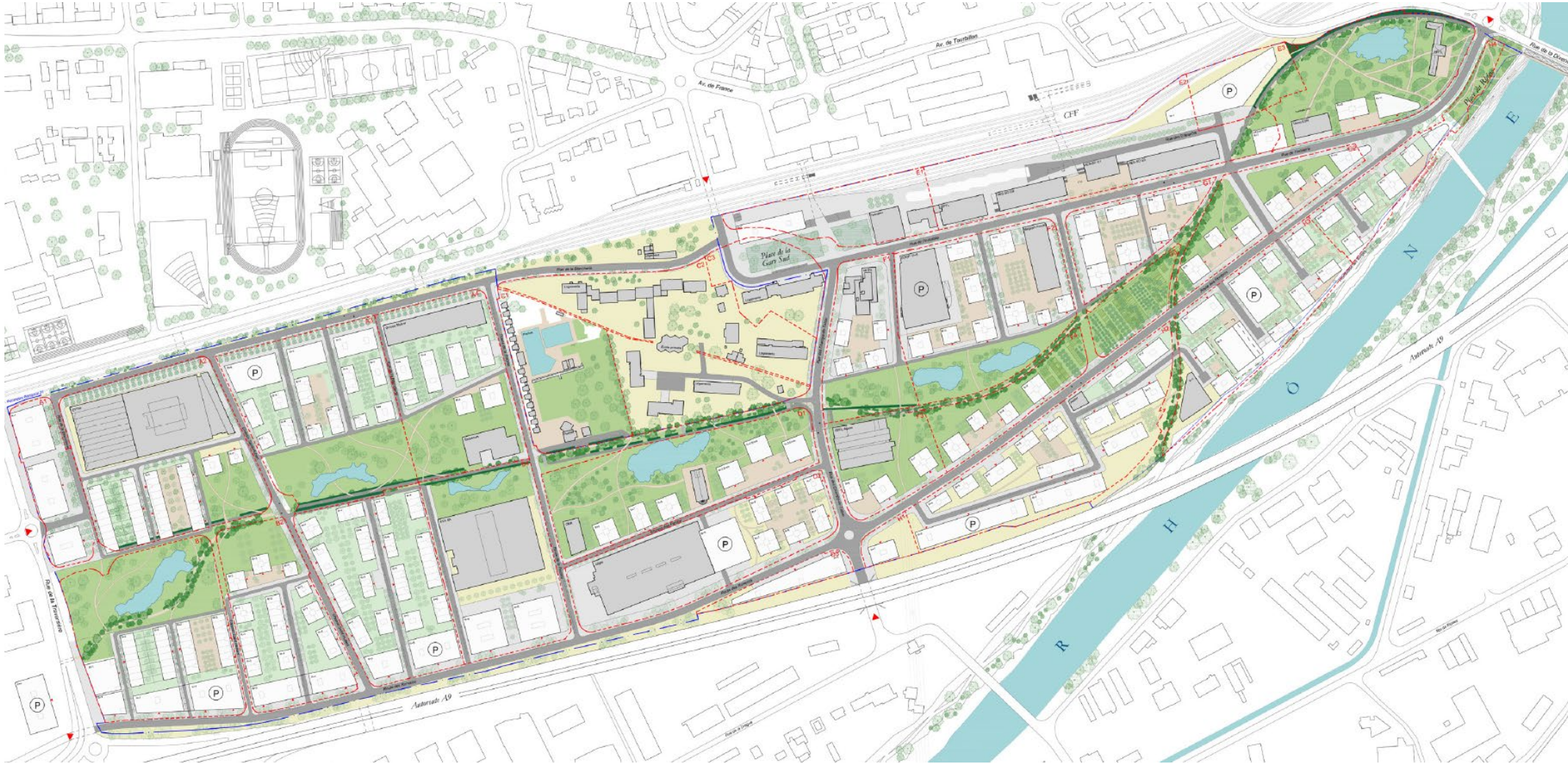

Urban Energy System of 2050

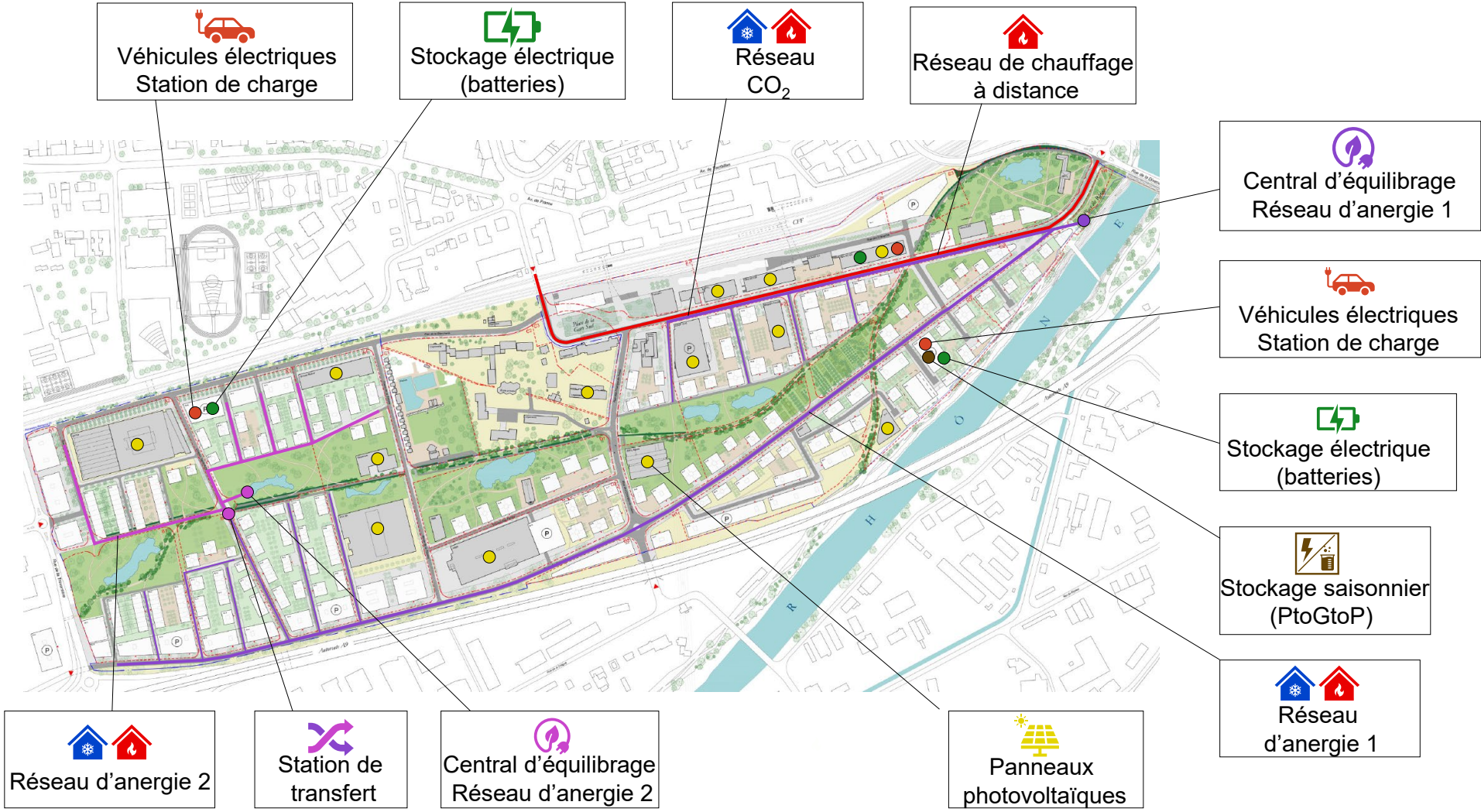

The net electricity flows of the neighbourhood

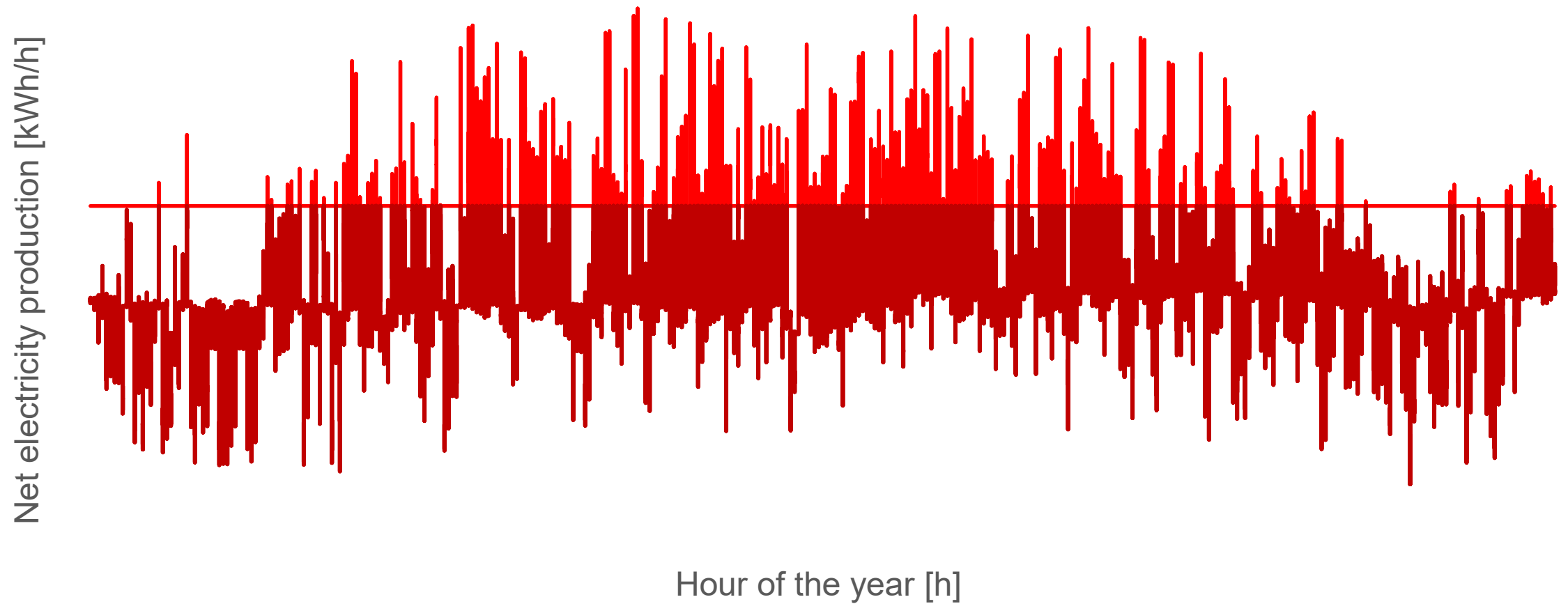

Research Platform for Integrated Urban Energy Systems

Electricity production and daily storage

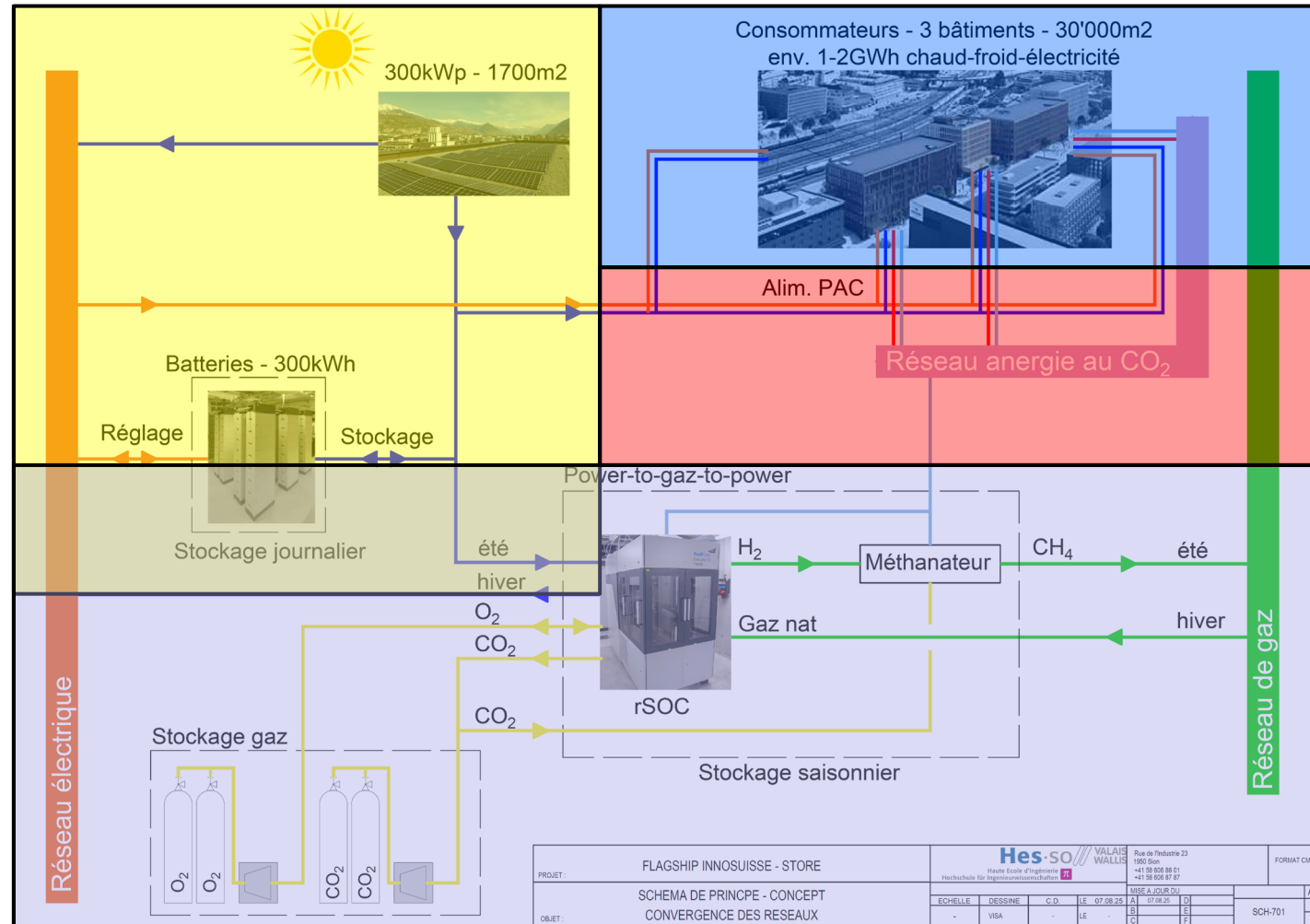

Energy consumers

Thermal distribution networks

Electricity conversion and seasonal storage



ELECTRICAL - Production, distribution & storage

- PV production
- Battery storage
- EV charging stations
- AC / DC networks



CHEMICAL – Power-to-Gas (Solid Oxide Electrolyser Cell)

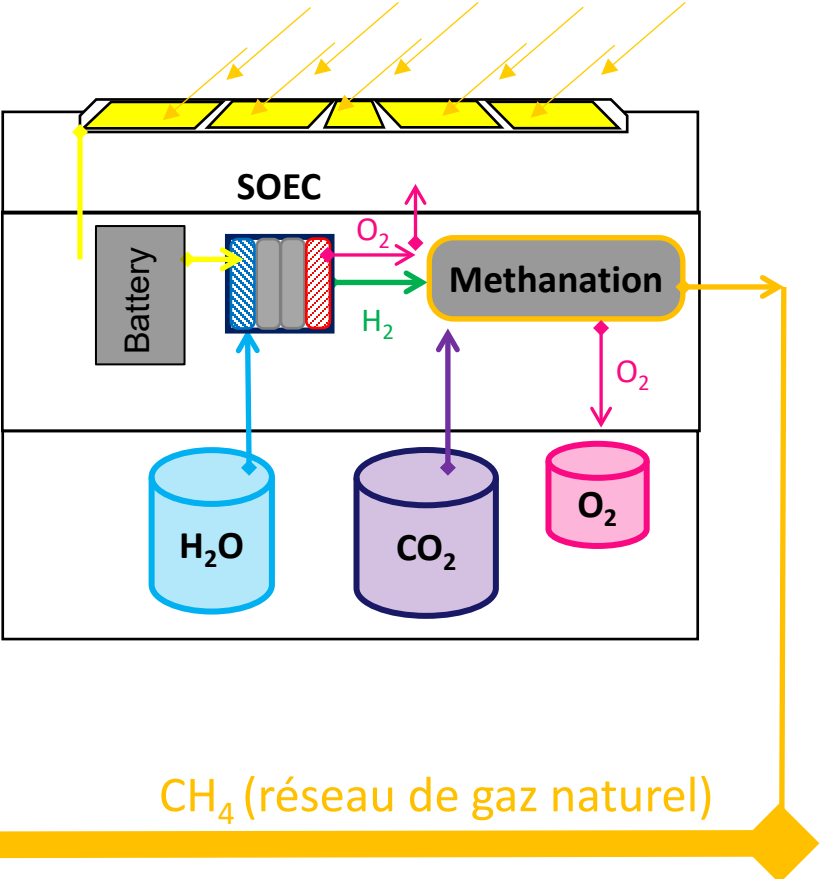

CHEMICAL – Gas-to-power: Solid Oxide Fuel Cell (SOFC) with CO₂ capture

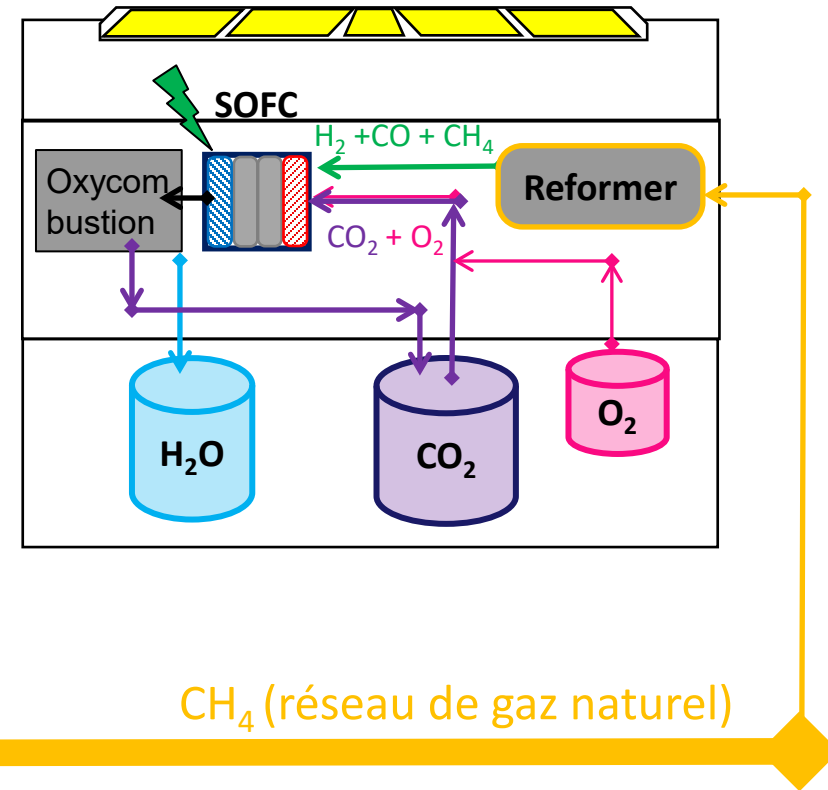

Power-to-gas (summer) combined with gas-to-power (winter)

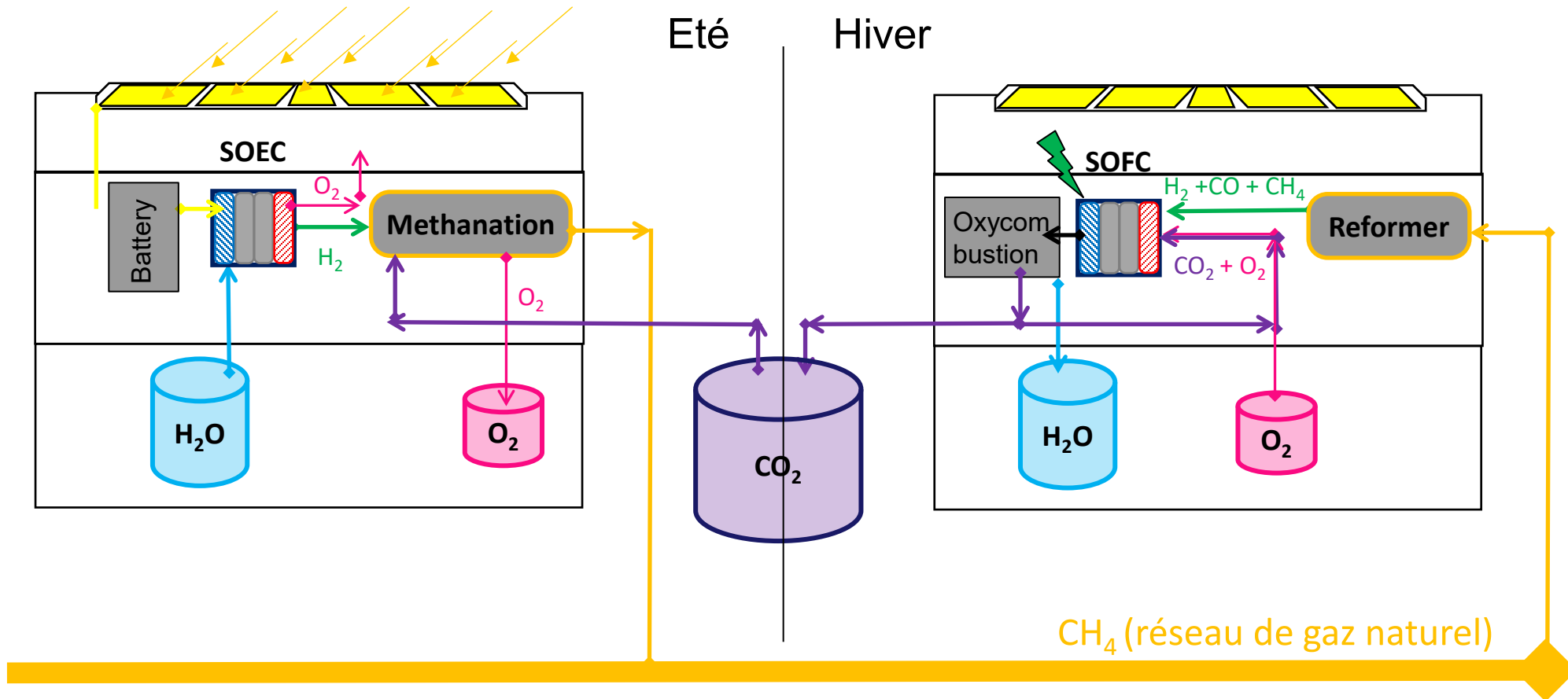

CHEMICAL – Closed-loop power-to-gas-to-power for seasonal storage

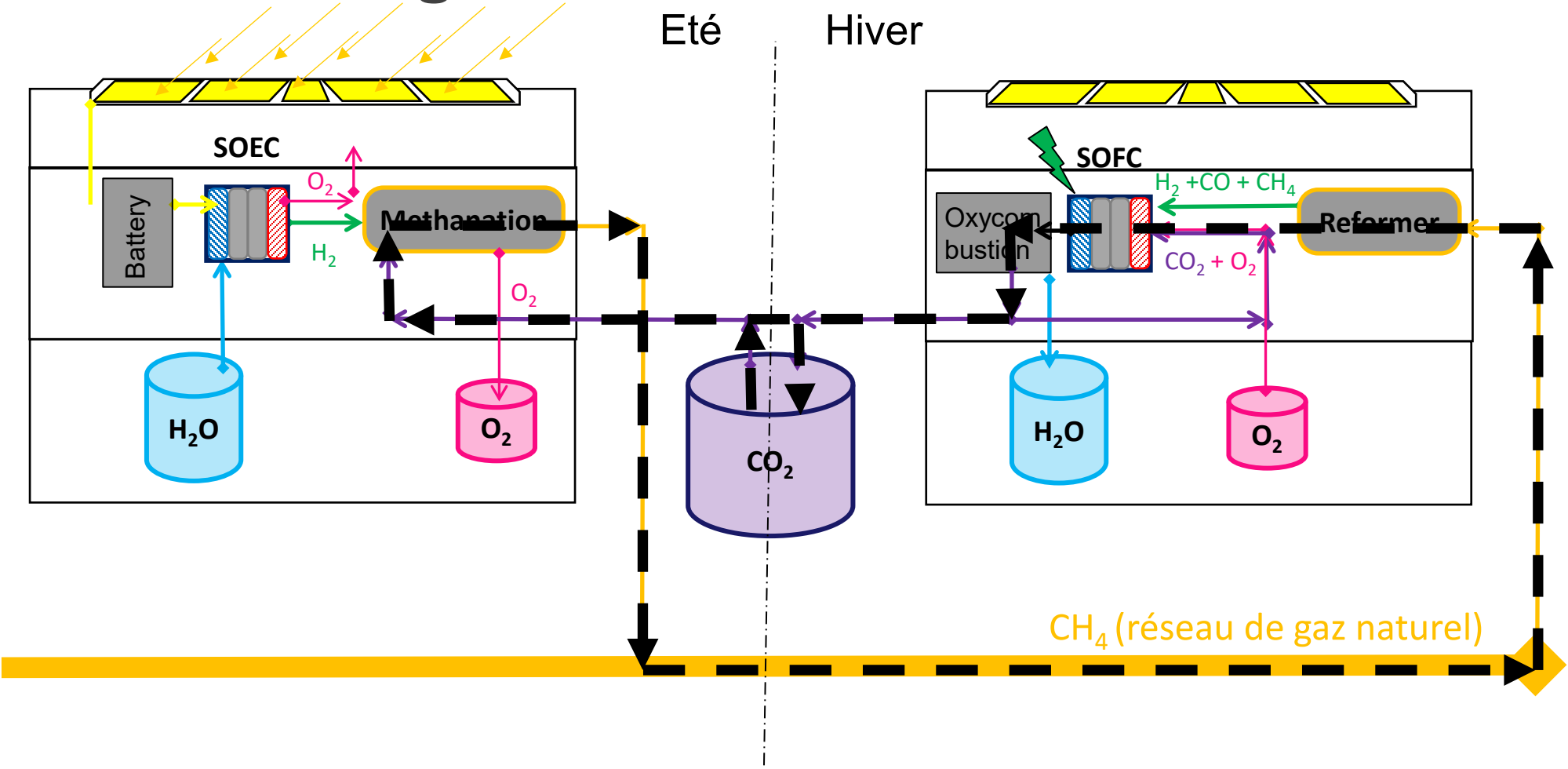

THERMAL - CO₂-based thermal network

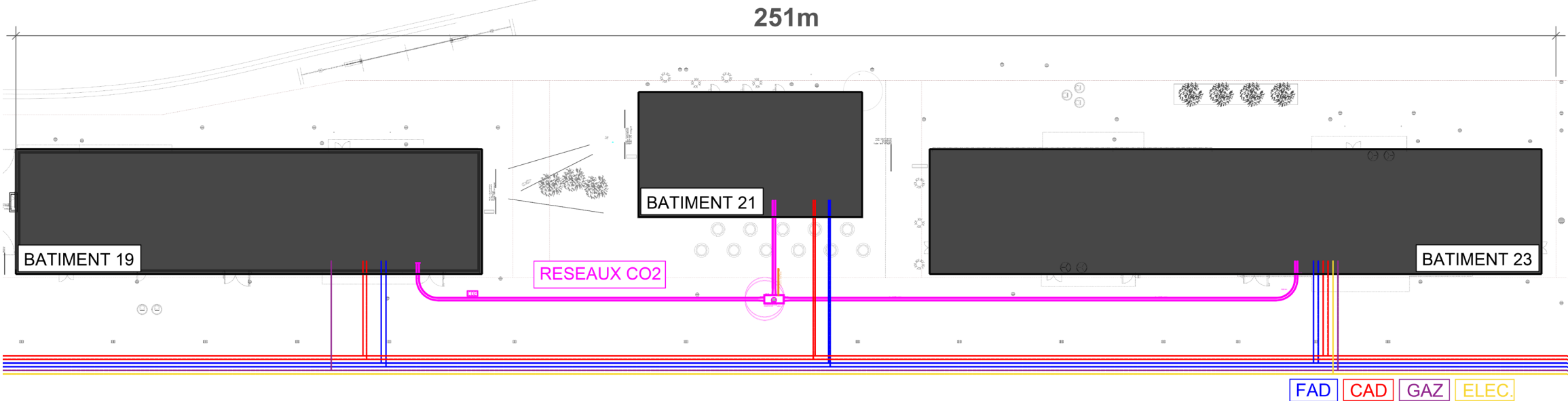

THERMAL - CO₂-based thermal network

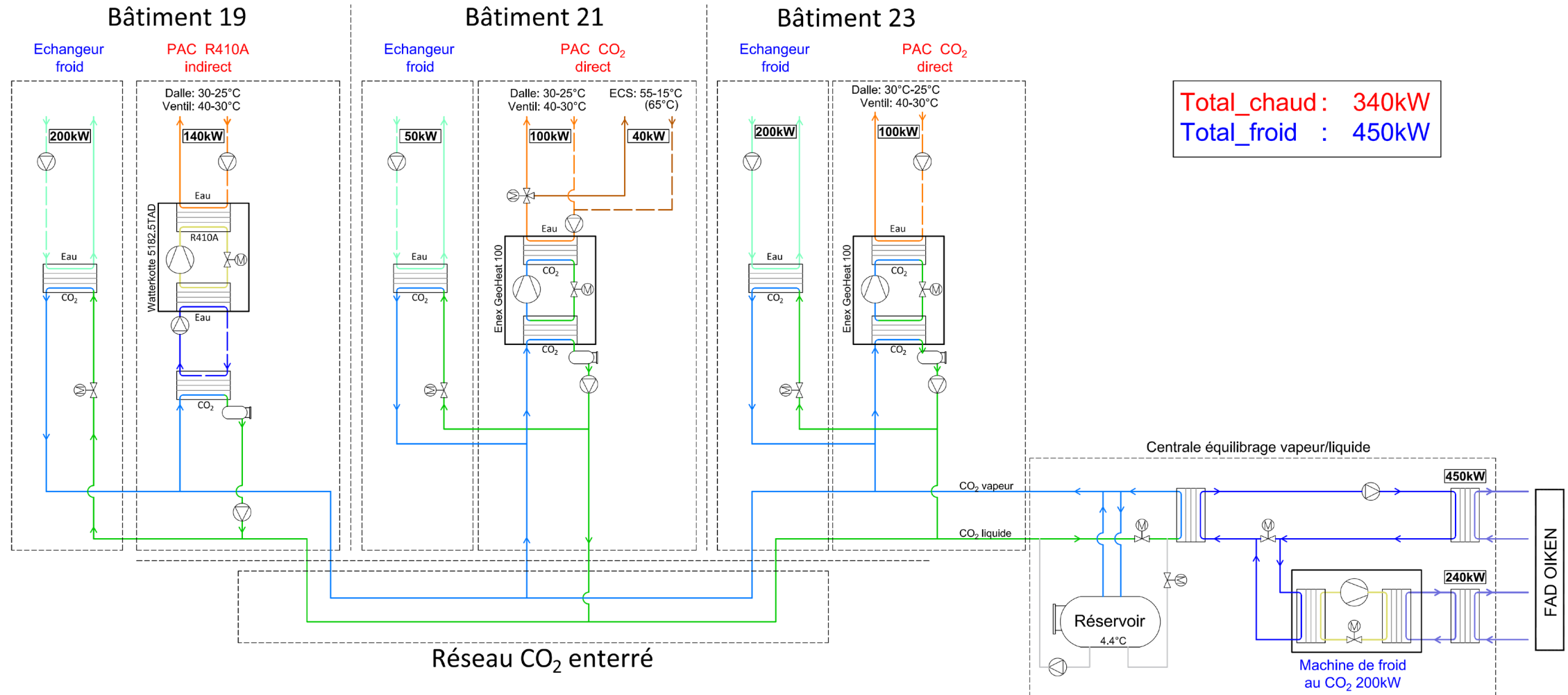

Total_chaud : 340kW
Total_froid : 450kW

